

KOMATSU®

WA380-6

HORSEPOWER
Gross: 143 kW 192 HP @ 2100 rpm
Net: 142 kW 191 HP @ 2100 rpm

BUCKET CAPACITY
2.7-4.0 m³ 3.5-5.2 yd³

ecot3

WA
380



WHEEL LOADER

Photo may include optional equipment.

WALK-AROUND

HORSEPOWER
 Gross: 143 kW 192 HP @ 2100 rpm
 Net: 142 kW 191 HP @ 2100 rpm

BUCKET CAPACITY
 2.7-4.0 m³ 3.5-5.2 yd³

High Productivity & Low Fuel Consumption

- High performance SAA6D107E-1 engine
- Low fuel consumption
- Dual-mode engine power select system
- Automatic transmission with shift timing select system
- Variable displacement piston pump & CLSS

See pages 4 and 5.

Excellent Operator Environment

- Automatic transmission with ECMV
- Electrically controlled transmission lever
- Variable transmission cut-off system
- Telescopic/tilt steering column
- Fingertip control levers
- Low-noise designed cab
- Pillar-less large ROPS/FOPS cab-integrated
- Easy entry/exit, rear-hinged doors

See pages 8 and 9.

Increased Reliability

- Reliable Komatsu designed and manufactured components
- Sturdy main frame
- Maintenance-free, fully hydraulic, wet disc service and parking brakes
- Hydraulic hoses use flat face O-ring seals

See page 6.

- Cathion electrodeposition process is used to apply primer paint
- Powder coating process is used to apply on main structure
- Sealed DT connectors for electrical connections



Photo may include optional equipment.

Harmony with Environment

- EPA Tier 3 and EU Stage 3A emissions certified
- Low exterior noise
- Low fuel consumption

Easy Maintenance

- "EMMS" (Equipment Management Monitoring System)

See page 7.

- Easy access, gull-wing type engine side doors
- Automatic Reversible Fan (option)

HIGH PRODUCTIVITY AND LOW FUEL CONSUMPTION



High Performance SAA6D107E-1 Engine

Electronic Heavy Duty Common Rail fuel injection system provides optimum combustion of fuel. This system also provides fast throttle response to match the machine's powerful tractive effort and fast hydraulic response.

Net: 142 kW 191 HP

Low Emission Engine

This engine is EPA Tier 3 and EU Stage 3A emissions certified, without sacrificing power or machine productivity.

Low Fuel Consumption

The fuel consumption is reduced greatly because of the low-noise, high-torque engine and the large-capacity torque converter with maximum efficiency in the low-speed range.

Dual-mode Engine Power Select System

This wheel loader offers two selectable operating modes—E and P. The operator can adjust the machine's performance with the selection switch.

- **E Mode:** This mode provides maximum fuel efficiency for most of general loading.
- **P Mode:** This mode provides maximum power output for hard digging operation or hill climb.



Dual mode engine power selection switch



Eco indicator

The eco indicator will help an operator to promote energy saving.

Automatic Transmission With Mode Select System

This operator controlled system allows the operator to select manual shifting or two levels of automatic shifting (low, and high).

Auto L mode is for fuel saving operation with the gear shift timing set at lower speeds than Auto H mode. Therefore Auto L mode keeps the engine run in a relatively low rpms range



Shift mode selection switch

for fuel conservation while yielding adequate tractive force by depressing the accelerator pedal.

Variable Displacement Piston Pump & CLSS

New design variable displacement piston pump combined with the Closed-center Load Sensing System delivers hydraulic flow just as the job requires preventing wasting hydraulic pressure. Minimized waste loss contributes to better fuel economy.

- **New Variable Displacement Piston Pump:** The pump delivers only necessary amounts minimizing waste loss.

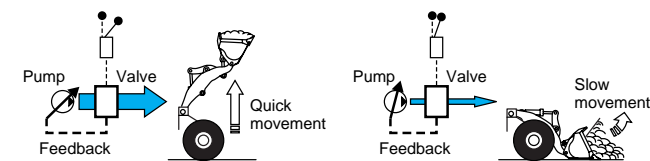

- **Fixed Displacement Piston Pump:** The pump delivers the maximum amount at any time and the unused flow is disposed.

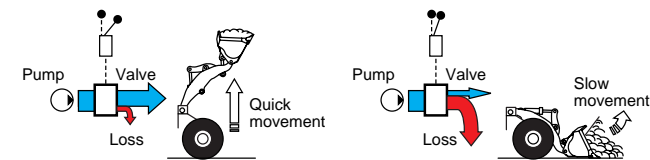

Maximum Dumping Clearance and Reach

The long lift arms provide high dumping clearances and maximum dumping reach. The operator can even level loads on the body of a dump truck easily and efficiently.

Dumping Clearance: 2885 mm 9'6"
Dumping Reach: 1210 mm 4'0"
(3.3 m³ 4.3 yd³ bucket with B.O.C.)



INCREASED RELIABILITY

Komatsu Components

Komatsu manufactures the engine, torque converter, transmission, hydraulic units, electric parts, and even each bolt on this wheel loader. Komatsu loaders are manufactured with an integrated production system under a strict quality control system.

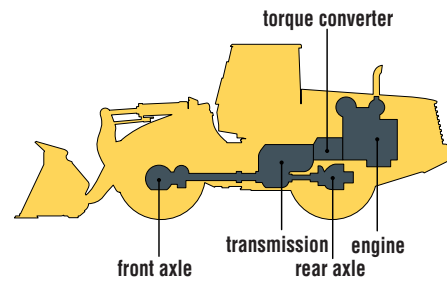

Wet Multi-disc Brakes and Fully Hydraulic Braking System

mean lower maintenance costs and higher reliability. Wet disc brakes are fully sealed. Contaminants are kept out, reducing wear and resulting maintenance. Brakes require no adjustments for wear, meaning even lower maintenance. The new parking brake is also an adjustment-free, wet multi-disc for high reliability and long life. Added reliability is designed into the braking system by the use of two independent hydraulic circuits. Provides hydraulic backup should one of the circuits fail. Fully hydraulic brakes mean no air system to bleed, or the condensation of water in the system that can lead to contamination, corrosion, and freezing.

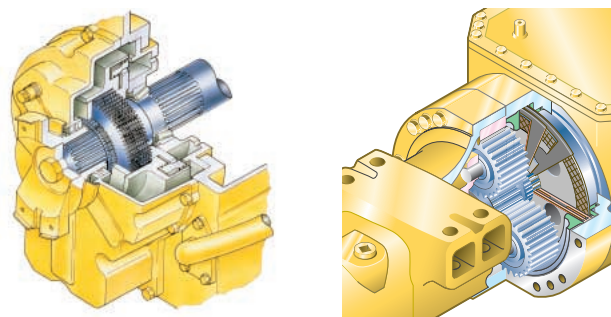

High-rigidity Frames and Loader Linkage

The front and rear frames and the loader linkage have got more torsional rigidity to secure resistance against stresses increased due to the use of a larger bucket. Frame and loader linkage are designed to accommodate actual working loads, and simulated computer testing proves its strength.

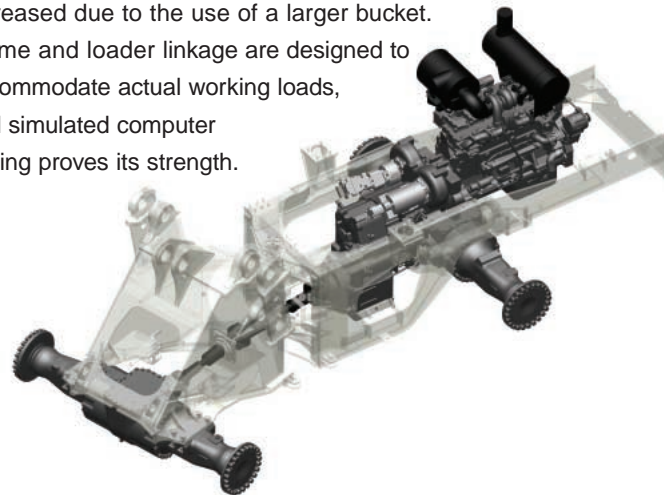

Flat Face-to-face O-ring Seals

Flat face-to-face O-ring seals are used to securely seal hydraulic hose connections and to prevent oil leakage. In addition, buffer rings are installed to the head side of the all-hydraulic cylinders to lower the load on the rod seals and maximize the reliability.

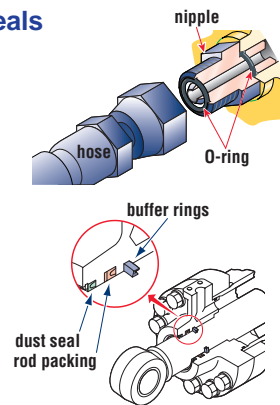

Cathion Electrodeposition Primer Paint/ Powder Coating Final Paint

Cathion electrodeposition paint is applied as a primer paint and powder coating is applied as topcoat to the exterior metal sheet parts. This process results in a beautiful rust-free machine, even in the most severe environments. Some external parts are made of plastic providing long life and high impact resistance.

Sealed DT Connectors

Main harnesses and controller connectors are equipped with sealed DT connectors providing high reliability, water resistance and dust resistance.



EASY MAINTENANCE



Photo may include optional equipment.

EMMS (Equipment Management Monitoring System)

Monitor is mounted in front of the operator for easy view, allowing the operator to easily check gauges and warning lights.



A specially designed two-spoke steering wheel allows the operator to easily see the instrument panel.

Maintenance Control and Troubleshooting Functions

- **Action code display function:** If the loader has any troubles, the monitor displays action details on the character display at the center bottom of the monitor.
- **Monitor function:** Controller monitors engine oil level, pressure, coolant temperature, air cleaner clogging, etc. If controller finds abnormalities, all of these are displayed on LCD.
- **Replacement time notice function:** Monitor informs replacement time of oil and filters on LCD when it reaches replacement intervals.
- **Trouble data memory function:** Monitor stores abnormalities for effective troubleshooting.

Gull-wing Type Engine Side Doors Open Wide

The operator can open and close each gull-wing type engine side door easily with the assistance of a gas spring to perform daily service checks from the ground.



Ease of Radiator Cleaning

If the machine is operating in adverse conditions, the operator can reverse the hydraulic cooling fan from inside the cab by turning on a switch on the control panel.

Automatic Reversible Fan (optional)

The engine fan is driven hydraulically. It can be operated in reverse automatically. When switch is automatic position. The fan revolves in reverse for 2minutes every 2 hours intermittently. (Default setting)

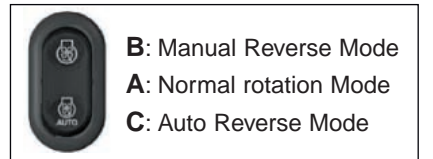

OPERATOR ENVIRONMENT

Easy Operation

Automatic Transmission with ECMV

Automatic transmission with ECMV automatically selects the proper gear speed based on travel speed, engine speed, and other travel conditions. The ECMV (Electronically Controlled Modulation Valve) system engages the clutch smoothly to prevent lags and shocks when shifting. This system provides efficient machine operation and a comfortable ride.

● Kick-down switch:

Consider this valuable feature for added productivity. With the touch of a finger, the kick-down switch

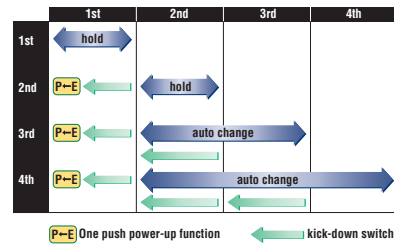

automatically downshifts from second to first when beginning the digging cycle. It automatically upshifts from first to second when the direction control lever is placed in reverse. This results in increased rim pull for better bucket penetration and reduced cycle times for higher productivity.

● **One push power-up function:** The kick-down switch also functions as a power-up switch in first gear. The first time the kick-down switch is depressed it functions as a kick-down switch and gear speed is reduced. When the machine is in E operation mode and first gear, pressing the kick-down switch a second time changes the operation mode to P allowing increased power for heavy digging operation. The operation mode returns to E when machine gear speed changes or direction changes to reverse.

● **Hold switch:** Auto shift is selected and if the operator turns on this switch when the lever is at the 3rd or 4th gear speed position, the transmission is fixed to that gear speed.

Electronically Controlled Transmission Lever



Easy shifting and directional changes

with Komatsu two-lever electronic shifting. Change direction or shift gears with a touch of the fingers without removing the

shifting hand from the steering wheel. Solid state electronics and conveniently located direction and gear shift controls make this possible. Automatic shifts in ranges two through four keep production high and manual shifting at a minimum.

Variable Transmission Cut-off System

The operator can continuously adjust the transmission cut-off pressure desired for the left brake pedal using switch located on the right-side control panel. The operator can improve the working performance by setting the cut-off pressure properly depending on working condition.

- High cut-off pressure for digging operations.
- Low cut-off pressure for truck-loading operations.



1:Cut-off ON/OFF switch 2:Cut off adjustment switch
3:Fan reverse ON/OFF switch 4:Boom control 5:Bucket control

Fingertip Work Equipment Control Levers with Large Size Arm Rest

New PPC control levers are used for the work equipment. The operator can easily operate the work equipment with fingertip control, reducing operator fatigue and increasing controllability. The PPC control lever column can be slid



forward or rearward and the large size arm rest can be adjusted up or down to provide the operator with a variety of comfortable operating positions.

Telescopic/Tilt Steering Column

The operator can tilt and telescope the steering column to provide a comfortable working position.



Photo may include optional equipment.

Comfortable Operation

Low-noise Design

Noise at operator's ear noise level : 72 dB(A)
Dynamic noise level (outside): 108 dB(A)

The large cab is mounted with Komatsu's unique ROPS/FOPS viscous mounts. The low-noise engine, hydraulically driven fan, and hydraulic pumps are mounted with rubber cushions, and the cab sealing is improved to provide a quiet, low-vibration, dustproof with pressurizing, and comfortable operating environment. Also, exterior noise is lowest in this class.

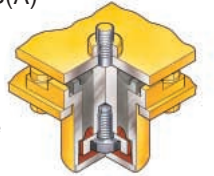

Pillar-less Large Cab

A wide pillar-less flat glass provides excellent front visibility. The wiper arm covers a large area to provide great visibility even on rainy days.

The cab area is the largest in its class providing maximum space for the operator. Increased seat reclining and slide adjustment to backward by introducing front mounted air conditioner unit.

Rear-hinged Full Open Cab Doors

The cab door hinges are installed to the rear side of the cab providing a large opening angle for the operator to enter and exit. The steps are designed like a staircase, so that the operator can get on and off the cab easily.



SPECIFICATIONS



ENGINE

ModelKomatsu SAA6D107E-1
 TypeWater-cooled, 4-cycle
 AspirationTurbocharged, aftercooled
 Number of cylinders6
 Bore x stroke107 mm x 124 mm 4.21" x 4.88"
 Piston displacement6.69 ltr 408 in³
 GovernorAll-speed, electronic
 Horsepower
 SAE J1995Gross 143 kW 192 HP
 ISO 9249/SAE J1349*Net 142 kW 191 HP
 Rated rpm2100 rpm
 Fan drive method for radiator coolingHydraulic
 Fuel systemDirect injection
 Lubrication system:
 MethodGear pump, force-lubrication
 FilterFull-flow type
 Air cleanerDry type with double elements and dust evacuator, plus dust indicator

*Net horsepower at the maximum speed of radiator cooling fan is 133 kW 179 HP.
 EPA Tier 3 and EU Stage 3A emissions certified.



TRANSMISSION

Torque converter:
 Type3-element, single-stage, single-phase
 Transmission:
 TypeAutomatic full-powershift, countershaft type
 Travel speed: km/h mph
 Measured with 20.5-25 tires

	1st	2nd	3rd	4th
Forward	6.0 3.7	10.6 6.7	18.6 11.6	31.1 19.3
Reverse	6.5 4.0	11.3 7.0	19.9 12.4	33.0 20.5

Measured with 23.5-25 tires

	1st	2nd	3rd	4th
Forward	6.6 4.1	11.5 7.1	20.2 12.6	34.0 21.1
Reverse	7.1 4.4	12.3 7.6	21.5 13.4	35.5 22.1



AXLES AND FINAL DRIVES

Drive systemFour-wheel drive
 FrontFixed, semi-floating
 RearCenter-pin support, semi-floating,
 26° total oscillation
 Reduction gearSpiral bevel gear
 Differential gearConventional type
 Final reduction gearPlanetary gear, single reduction



BRAKES

Service brakesHydraulically actuated,
 wet disc brakes actuate on four wheels
 Parking brakeWet disc brake
 Emergency brakeParking brake is commonly used



STEERING SYSTEM

TypeArticulated type, full-hydraulic power steering
 Steering angle35° each direction (40° end stop)
 Minimum turning radius at the center of outside tire6320 mm 20'9"



HYDRAULIC SYSTEM

Steering system:
 Hydraulic pumpPiston pump
 Capacity138 ltr/min 36.5 U.S. gal/min at rated rpm
 Relief valve setting24.5 MPa 250 kgf/cm² 3,555 psi
 Hydraulic cylinders:
 TypeDouble-acting, piston type
 Number of cylinders2
 Bore x stroke75 mm x 442 mm 3.0" x 17.4"

Loader control:
 Hydraulic pumpPiston pump
 Capacity205.5 ltr/min 54.3 U.S. gal/min
 Relief valve setting31.4 MPa 320 kgf/cm² 4,550 psi
 Hydraulic cylinders:
 TypeDouble-acting, piston type
 Number of cylinders—bore x stroke:
 Lift cylinder2- 130 mm x 713 mm 5.1" x 28.1"
 Bucket cylinder1- 150 mm x 535 mm 5.9" x 21.1"
 Control valve2-spool type
 Control positions:
 BoomRaise, hold, lower, and float
 BucketTilt-back, hold, and dump
 Hydraulic cycle time (rated load in bucket)
 Raise5.9 sec
 Dump1.8 sec
 Lower (Empty)3.3 sec



SERVICE REFILL CAPACITIES

Cooling system30.5 ltr 8.1 U.S. gal
 Fuel tank300 ltr 79.3 U.S. gal
 Engine23 ltr 6.1 U.S. gal
 Hydraulic system139 ltr 36.6 U.S. gal
 Axle (each front and rear)40 ltr 10.6 U.S. gal
 Torque converter and transmission38 ltr 10.0 U.S. gal



BUCKET SELECTION GUIDE

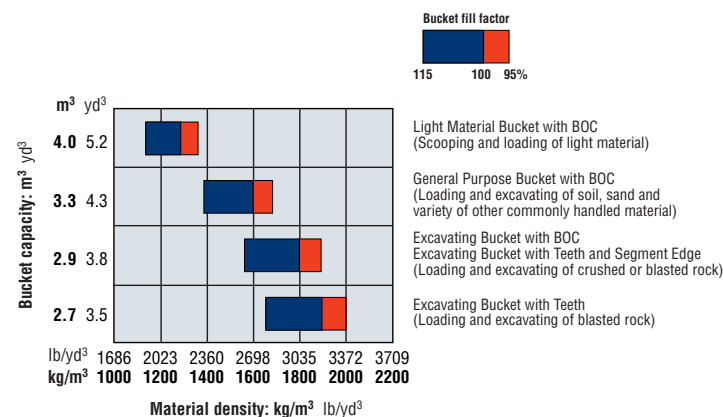

DIMENSIONS

Measured with 20.5-25-16PR (L3) tires, ROPS/FOPS cab

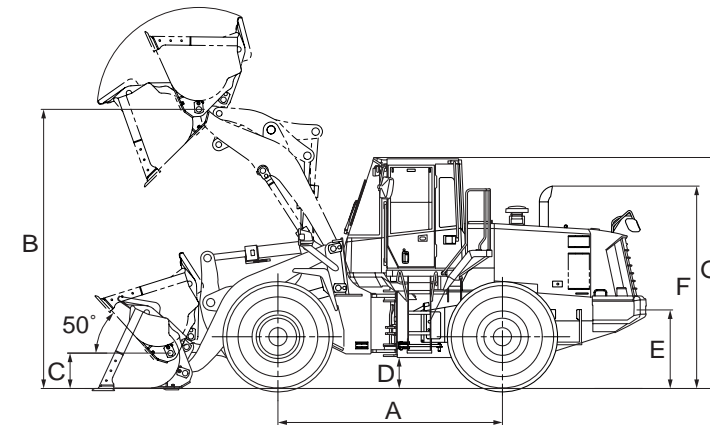

Tread	2160 mm	7'1"
Width over tires	2695 mm	8'10"
A Wheelbase	3300 mm	10'10"
B Hinge pin height, max. height	4030 mm	13'3"
C Hinge pin height, carry position	520 mm	1'8"
D Ground clearance	390 mm	1'3"
E Hitch height	1085 mm	3'7"
F Overall height, top of the stack	2910 mm	9'7"
G Overall height, ROPS cab	3325 mm	10'11"

	General Purpose Buckets		Excavating Buckets			Light Material Bucket
	Bolt-on Cutting Edges	Teeth	Bolt-on Cutting Edges	Teeth and Segments	Teeth	Bolt-on Cutting Edges
Bucket capacity: heaped	3.3 m ³ 4.3 yd ³	3.1 m ³ 4.1 yd ³	2.9 m ³ 3.8 yd ³	2.9 m ³ 3.8 yd ³	2.7 m ³ 3.5 yd ³	4.0 m ³ 5.2 yd ³
struck	2.9 m ³ 3.8 yd ³	2.7 m ³ 3.5 yd ³	2.4 m ³ 3.1 yd ³	2.4 m ³ 3.1 yd ³	2.3 m ³ 3.0 yd ³	3.4 m ³ 4.4 yd ³
Bucket width	2905 mm 9'6"	2925 mm 9'7"	2905 mm 9'6"	2925 mm 9'7"	2925 mm 9'7"	2905 mm 9'6"
Bucket weight	1620 kg 3,570 lb	1540 kg 3,395 lb	1720 kg 3,790 lb	1765 kg 3,890 lb	1645 kg 3,625 lb	1835 kg 4,045 lb
Dumping clearance, max. height and 45° dump angle*	2885 mm 9'6"	2755 mm 9'0"	2960 mm 9'9"	2840 mm 9'4"	2840 mm 9'4"	2790 mm 9'2"
Reach at max. height and 45° dump angle*	1210 mm 4'0"	1305 mm 4'3"	1125 mm 3'8"	1225 mm 4'0"	1225 mm 4'0"	1295 mm 4'3"
Reach at 2130 mm (7') clearance and 45° dump angle	1760 mm 5'9"	1790 mm 5'10"	1720 mm 5'8"	1755 mm 5'9"	1755 mm 5'9"	1800 mm 5'11"
Reach with arm horizontal and bucket level	2650 mm 8'8"	2810 mm 9'3"	2510 mm 8'3"	2680 mm 8'10"	2680 mm 8'10"	2775 mm 9'1"
Operating height (fully raised)	5535 mm 18'2"	5535 mm 18'2"	5420 mm 17'9"	5420 mm 17'9"	5420 mm 17'9"	5670 mm 18'7"
Overall length	8195 mm 26'11"	8365 mm 27'5"	8055 mm 26'5"	8225 mm 27'0"	8225 mm 27'0"	8320 mm 27'4"
Loader clearance circle (bucket at carry, outside corner of bucket)	14440 mm 47'5"	14550 mm 47'9"	14370 mm 47'2"	14480 mm 47'6"	14480 mm 47'6"	14500 mm 47'7"
Digging depth: 0°	125 mm 4.9"	140 mm 5.5"	125 mm 4.9"	140 mm 5.5"	140 mm 5.5"	125 mm 4.9"
10°	360 mm 1'2"	400 mm 1'4"	335 mm 1'1"	380 mm 1'3"	380 mm 1'3"	380 mm 1'3"
Static tipping load: straight	13880 kg 30,600 lb	13970 kg 30,800 lb	13780 kg 30,380 lb	13710 kg 30,230 lb	13870 kg 30,580 lb	13640 kg 30,070 lb
40° full turn	12000 kg 26,460 lb	12100 kg 26,680 lb	11900 kg 26,230 lb	11840 kg 26,100 lb	12000 kg 26,460 lb	11770 kg 25,950 lb
Breakout force	158 kN 16100 kgf 35,495 lb	170 kN 17300 kgf 38,140 lb	176 kN 18000 kgf 39,680 lb	183 kN 18700 kgf 41,225 lb	191 kN 19500 kgf 42,990 lb	144 kN 14700 kgf 32,405 lb
Operating weight	16610 kg 36,620 lb	16540 kg 36,460 lb	16720 kg 36,860 lb	16760 kg 36,950 lb	16650 kg 36,710 lb	16850 kg 37,150 lb

* At the end of tooth or B.O.C.

All dimensions, weights, and performance values based on SAE J732c and J742b standards.

Static tipping load and operating weight shown include lubricant, coolant, full fuel tank, ROPS cab, and operator. Machine stability and operating weight affected by counterweight, tire size, and other attachments.

Apply the following weight changes to operating weight and static tipping load.



WEIGHT CHANGES

Tires or attachments	Operating weight		Tipping load straight		Tipping load full turn		Width over tires		Ground clearance		Change in vertical dimensions	
	kg	lb	kg	lb	kg	lb	mm	ft in	mm	ft in	mm	ft in
20.5-25-16PR(L-3)	0	0	0	0	0	0	2695	8'10"	390	1'3"	0	0
23.5-25-16PR(L-3)	+970	+2,140	+770	+1,700	+680	+1,500	2780	9'1"	455	1'6"	+65	+3"
Install additional counterweight	+340	+750	+900	+1,985	+755	+1,665						



STANDARD EQUIPMENT

- 2-spool valve for boom and bucket controls
- Alternator, 60 A
- Auto shift transmission with mode select system
- Back-up alarm
- Back-up lamp
- Batteries, **136 Ah/2** x 12 V
- Boom kick-out
- Bucket positioner
- Counterweight
- Directional signal
- Engine, Komatsu SAA6D107E-1 diesel
- Engine shut-off system, electric
- Front fender
- Fuel prefilter with water separator
- Hydraulic-driven fan with reverse rotation
- Lift cylinders and bucket cylinder
- Loader linkage with standard lift boom
- Main monitor panel with EMMS (Equipment Management Monitoring System)
- PPC fingertip control, two levers
- Radiator mask, lattice type
- Rear defroster (electric)
- Rear view mirror
- Rear window washer and wiper
- ROPS/FOPS cab
- Seat, suspension type with reclining
- Seat belt
- Service brakes, wet disc type
- Starting motor, **5.5 kW/24** V
- Steering wheel, tiltable, telescopic
- Sun visor
- Tires (20.5-25-16PR, L3 tubeless) and rims
- Transmission, 4 forward and 4 reverse



OPTIONAL EQUIPMENT

- 3-spool valve
- Additional counterweight
- Air conditioner
- AM/FM radio
- AM/FM stereo radio cassette
- Auto air conditioner
- Batteries, **140 Ah/2** x 12V
- Bucket teeth (bolt-on type)
- Bucket teeth (tip type)
- Counterweight for log
- Cutting edge (bolt-on type)
- Deluxe suspension seat
- ECSS (Electronically Controlled Suspension System)
- Emergency steering (SAE)
- Engine pre-cleaner with extension
- Floor mat
- High lift boom
- Joystick steering
- Limited slip differential (F&R)
- Lock-up clutch torque converter
- Log grapple
- Ordinary spare parts
- Power train guard
- Rear fender
- Tool kit
- Vandalism protection kit

www.Komatsu.com

Printed in Japan 201302 IP.SIN

KOMATSU®

CEN00076-05

Materials and specifications are subject to change without notice
KOMATSU is a trademark of Komatsu Ltd. Japan