

# KOMATSU®

## WA200-5

**FLYWHEEL HORSEPOWER**  
Gross: 95 kW 127 HP @ 2000 rpm  
Net: 92 kW 123 HP @ 2000 rpm

**OPERATING WEIGHT**  
9425 – 9555 kg  
20,779 – 21,065 lb

**BUCKET CAPACITY**  
1.7 – 2.4 m<sup>3</sup> 2.2 – 3.1 yd<sup>3</sup>

**WA**  
**200**



Photo may include optional equipment.

**WA200**

**WHEEL LOADER**

**WA200-5 WHEEL LOADER**

# WALK-AROUND

## GALEO

Building on the technology and expertise Komatsu has accumulated since its establishment in 1921, GALEO presents customers worldwide with a strong, distinctive image of technological innovation and exceptional value. The GALEO brand will be employed for Komatsu's full lineup of advanced construction and mining equipment. Designed with high productivity, safety and environmental considerations in mind, the machines in this line reflect Komatsu's commitment to contributing to the creation of a better world.

***Genuine Answers for Land and Environment Optimization***

***Komatsu-integrated design*** offers the best value, reliability, and versatility. Hydraulics, powertrain, frame, and all other major components are engineered by Komatsu. You get a machine whose components are designed to work together for higher production, greater reliability, and more versatility.

***Maintenance-free*** fully hydraulic wet-disc service and parking brakes

***Electronically controlled Hydrostatic Transmission (HST)*** with variable shift control system

***Traction control system***

***Reduced operator noise***  
to 70 dB(A)

***Expanded main monitor***  
and troubleshooting display

***Larger cab***  
with new layout design

***New tilt*** steering column

***Easy-to-operate loader control mono-lever***  
using PPC (Proportional Pressure Control)



***Large breakout force***

***Extended service intervals***

## WHEEL LOADER

# WA200-5

**FLYWHEEL HORSEPOWER**  
Gross: 95 kW 127 HP @ 2000 rpm  
Net: 92 kW 123 HP @ 2000 rpm

**OPERATING WEIGHT**  
9425 – 9555 kg  
20,779 – 21,065 lb

**BUCKET CAPACITY**  
1.7 – 2.4 m<sup>3</sup>  
2.2 – 3.1 yd<sup>3</sup>

Powerful yet efficient Komatsu  
SAA6D102E-2-A *emissionized engine*

*Full side opening*  
gull-wing engine doors



*Radial Sealed*  
air cleaner

*Swing-out hydraulic*  
radiator fan

*Side-by-side type coolers*  
for easy access and cleaning

*Overrun protection system*

*Ground level servicing*  
and fluid checks

*Extremely low*  
fuel consumption

*Flat face "O-Ring" Hydraulic Seals*  
for extended life

*Staircase-type steps*  
with large rear-hinged doors

*Sealed DT electrical connectors*

Photos may include optional equipment.

# PRODUCTIVITY FEATURES

## High Productivity and Low Fuel Consumption

### Powerful Engine

A powerful SAA6D102E-2 turbocharged air-to-air after-cooled diesel engine provides an output (net) of **92 kW** 123 HP for the WA200-5. This engine meets Tier 2 EPA, EU and Japanese emission regulations without sacrificing power or machine productivity.

### Low Fuel Consumption

The fuel consumption is reduced up to 15%\* due to the high-torque engine and Hydrostatic Transmission (HST) with maximum efficiency in the low-speed range.

\*V-shape loading (25 sec. cycle time)

### Electronically-Controlled HST Using a 1-Pump, 2-Motor System

- The 1-pump, 2-motor system allows for high-efficiency and high tractive effort. Engine power is transmitted hydraulically to a transfer case, then manually out to the differentials and out to the four driving wheels.
- HST provides quick travel response and aggressive drive into the pile. The variable displacement system automatically adjusts to the tractive effort demand to provide maximum power and efficiency.
- Full auto-shifting eliminates any gear shifting and kick-down operation to allow the operator to concentrate on digging and loading.

- When high drive torque is needed for digging, climbing or initiating movement, the pump feeds both motors. This combination makes the loader very aggressive and quick.
- Under deceleration, the HST system acts as a dynamic brake on the mechanical drive system. The dynamic brake can hold the loader in position on most workable slopes. This can be an advantage in stockpiling and ramp loading.
- As the machine moves and gains ground speed, the torque demand decreases and the low speed motor is effectively removed from the drive system by a clutch. At this point, the flow is going to the high-speed motor and the low-speed motor is not causing a drag on the system.
- An inching pedal gives the operator excellent simultaneous control of his travel and equipment hydraulic speeds. By depressing the inching pedal, drive pump flow to the motors will decrease, reducing ground speed and allowing the operator to use his accelerator to increase flow to his equipment hydraulics. Depressing the inching pedal further will activate the service brakes.

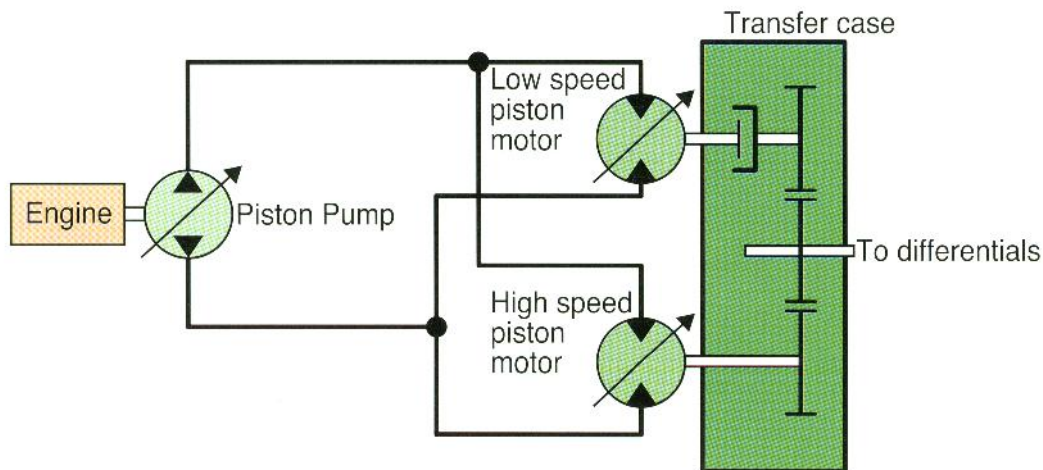

**Electronically-Controlled HST with Variable Shift Control System**

The operator can choose between first, second, third or fourth maximum speeds by dialing the speed range selector switch.

For v-cycles, the operator can set the speed control switch to 1 or 2, which will give him aggressive digging, quick response and fast hydraulics. For load and carry, he can select 3 or 4 which will still give aggressive digging but with much faster travel speed.



The variable shift switch allows the operator to adjust his machine speed in confined v-loading applications. When in 1, the operator can adjust his travel speed using the variable shift switch to match his machine speed and hydraulics to the distance he must travel.

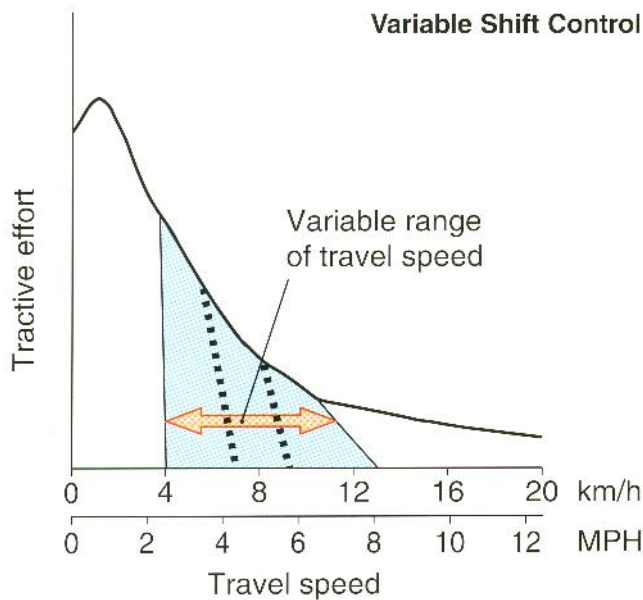

**Traction Control System**

In limited traction situations where the operator would like to avoid tire slippage (such as sandy or wet surface operations), he can automatically reduce slippage by activating the traction control feature. Putting the traction control switch in the "ON" position limits the maximum amount of tractive effort.

Traction control will be an advantage in certain applications such as transfer stations where the loader may be working on slippery concrete.

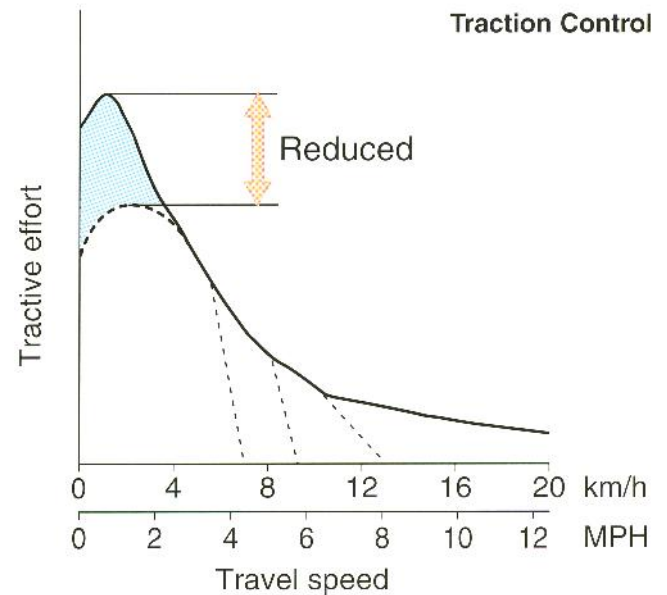

## INCREASED RELIABILITY AND SERVICEABILITY

### Main Monitor - EMMS (Equipment Management Monitoring System)

Komatsu's new main monitor keeps the operator informed of all machine functions at a glance. The monitor is located behind the steering wheel and displays various different machine functions including fluid/filter change intervals and troubleshooting memory display functions. The main gauges are analog type for easy viewing and other functions utilize light symbols or LCD readouts.



### Swing-Out Radiator

The new Komatsu cooling system is isolated from the engine to provide more efficient cooling and low noise. The swing-out hydraulic fan allows the operator to quickly clean out the cooling system.



The radiator, air-to-air cooler and oil cooler are mounted side-by-side for more efficient cooling and easy cleaning. A fully-opening, gas spring assisted rear grill gives the operator excellent access to the swing-out fan and coolers.

### Full Side-Opening Gull-Wing Engine Doors

Ground level engine service and daily service checks are made easy with the gas spring assisted full side opening gull-wing doors.



### Extended Service Interval

Extended engine oil change interval:

250 H → 500 H

Extended drive shaft greasing interval:

1,000 H → 4,000 H



### Overrun Prevention System

When the machine descends a slope of six degrees or less, maximum travel speed is automatically restricted to approximately **38 km/h** 24 MPH, for safety protection against damage of power train components and brakes by sensing the travel speed and controlling the discharge amount of the HST pump and motor. When the machine descends a steep slope and the travel speed reaches **36 km/h** 22 MPH, the caution lamp lights up to inform the operator to reduce the travel speed.

Note: When the machine descends a steep slope, the use of the service brake is necessary to limit travel speed.

**Fully Hydraulic Wet Multi-disc Service Brakes**

The dual wet disc brakes at each wheel are fully sealed and adjustment free to reduce contamination, wear and maintenance. The result is lower maintenance costs and higher reliability.

Added dependability is designed into the braking system by the use of two independent hydraulic circuits, providing hydraulic backup should one of the circuits fail.

If the brake oil pressure drops, the warning lamp flashes and the warning buzzer sounds intermittently.

The parking brake is mechanically controlled by a lever in the cab.

**Parking Brake**

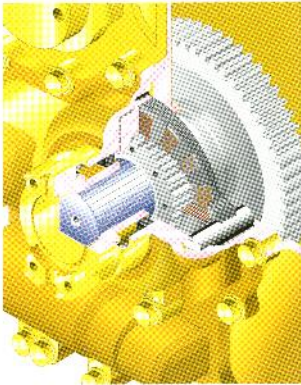

**Service Brakes**

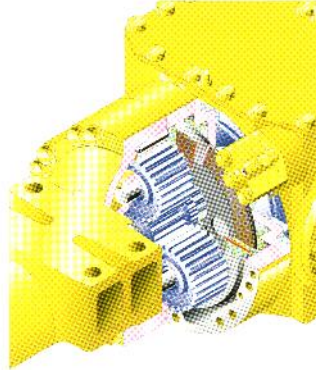

**High-rigidity Frames**

The front and rear frames along with the loader linkage have high rigidity to withstand repeated twisting and bending loads to the loader body and linkage. Both the upper and lower center pivot bearings use tapered roller bearings for increased durability. The structure is similar to those of large sized loaders and the reinforced loader linkage ensures high strength.

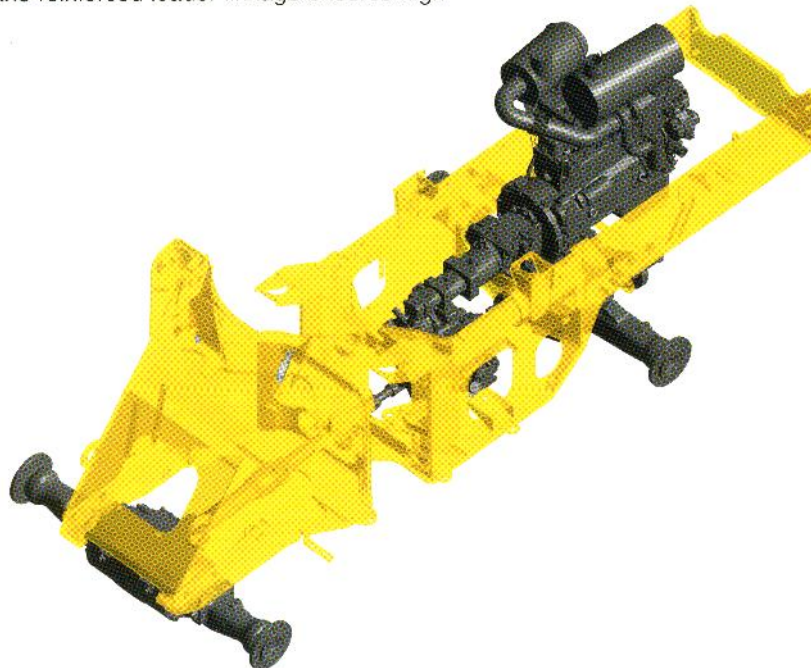

**Flat Face-to-Face O-Ring Seals**

Flat face-to-face O-ring seals are used to securely seal all hydraulic hose connections and to prevent oil leakage.

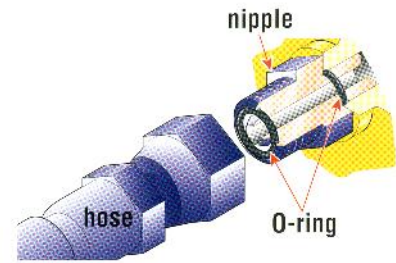

**Cathion Electrodeposition Primer Paint/Powder Coating Final Paint**

Cathion electrodeposition paint is applied as a primer paint and powder coating is applied as a topcoat to the exterior metal sheet parts. This process results in a durable rust-free machine, even in the most severe environments. Some external parts are made of plastic to provide long life and high impact resistance.

**Sealed DT Connectors**

Main harnesses and controller connectors are equipped with sealed DT connectors providing high reliability and dust and corrosion resistance.

**Komatsu Components**

Komatsu manufactures the engine, transfer case, differentials and electric parts on this wheel loader. Komatsu loaders are manufactured with an integrated production system under a strict quality control system.

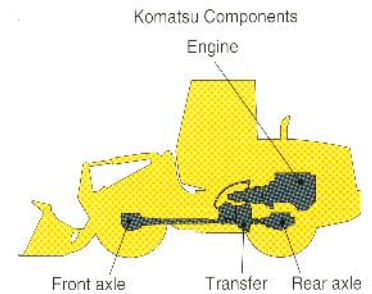

## OPERATOR COMFORT

### New Cab Layout

Komatsu's new cab layout provides the operator with a roomy, quiet and efficient work environment. The low noise level inside the cab leads the industry at 70 dB(A) and loader controls are ergonomically designed to reduce operator fatigue and increase productivity.

### Two Door Walk-Through Cab

Entry and exit into the new Komatsu cab starts with sloped staircase type steps and large diameter handrails for added safety and comfort. The large cab doors are rear-hinged to open 130 degrees offering easy entry/exit and will not hamper visibility when operating the machine with the doors latched open. A wide pillar-less flat glass provides for excellent visibility. The wiper arm covers a large area to provide great visibility even on rainy days.



### Low-noise Design

Operator noise: 70 dB(A)

The large cab is mounted with Komatsu's unique ROPS/FOPS viscous mounts. The low-noise engine, hydraulically driven fan, and hydraulic pumps are mounted with rubber cushions, and the cab sealing is improved to provide a quiet, low-vibration, and comfortable operating environment. Pressurization in the cab keeps dirt out further enhancing the operator's comfort.

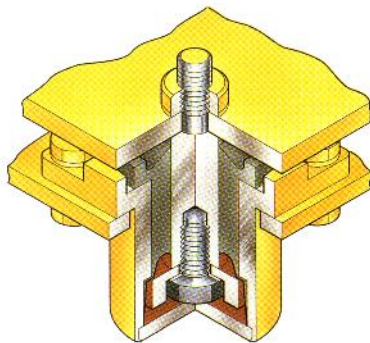

### Easy-to-operate Loader Control Mono-lever

A new mono-lever using PPC (Proportional Pressure Control) allows the operator to easily operate the work equipment, to reduce operator fatigue and to increase controllability. The adjustable wrist rest provides the operator with a variety of comfortable operating positions.



### Electrically Controlled Directional Lever

The operator can change direction with a touch of his fingers without removing his hand from the steering wheel. Solid state electronics makes this possible.





### Tiltable Steering Column

The operator can tilt the steering column to allow maximum comfort and control. The two-spoke steering wheel allows maximum visibility of the monitor panel and forward work environment.



### Comforts of Home

The large cab allows room for a large lunch box holder, a variety of cup holders and a hot/cold box storage area. Optional air conditioning and the optional AM/FM stereo cassette system create a comfortable and controlled work environment.



# WA200-5 WHEEL LOADER

## SPECIFICATIONS



### ENGINE

Model.....Komatsu SAA6D102E-2-A  
 Type.....Water-cooled, 4-cycle  
 Aspiration.....Turbocharged, and air-to-air aftercooled  
 Number of cylinders.....6  
 Bore x stroke.....102 mm x 120 mm 4.02" x 4.72"  
 Piston displacement.....5.88 ltr 359 in<sup>3</sup>  
 Governor.....Mechanical, all-speed control  
 Flywheel horsepower  
 ISO 9249 / SAE J1349.....Gross 95 kW 127 HP  
 Net 92 kW 123 HP  
 Rated rpm.....2000 rpm

Meets EPA emissions regulations

Fuel system.....Direct injection  
 Lubrication system  
 Method.....Gear pump, force-lubrication  
 Filter.....Full-flow  
 Air cleaner.....Dry-type with double radial-sealed elements  
 and dust evacuator, plus dust indicator



### TRANSMISSION

Transmission.....Hydrostatic, 1 pump, 2 motors  
 with speed range select

Travel speed (Both Forward and Reverse)

|      | 17.5-25 tires   |               | 20.5-25 tires   |               |
|------|-----------------|---------------|-----------------|---------------|
| 1st* | 4.0 - 13.0 km/h | 2.5 - 8.1 mph | 4.4 - 14.3 km/h | 2.7 - 8.9 mph |
| 2nd  | 13.0 km/h       | 8.1 mph       | 14.3 km/h       | 8.9 mph       |
| 3rd  | 20.0 km/h       | 12.4 mph      | 22.0 km/h       | 13.7 mph      |
| 4th  | 34.5 km/h       | 21.4 mph      | 38.0 km/h       | 23.6 mph      |

\*1st speed can be set variably



### AXLES AND FINAL DRIVES

Drive system.....Four-wheel drive  
 Front.....Fixed, semi-floating  
 Rear.....Center-pin support, semi-floating  
 24° total oscillation  
 Reduction gear.....Spiral bevel gear  
 Differential gear.....Torque proportioning  
 Final reduction gear.....Planetary gear, single reduction



### BRAKES

**Service brakes:** Hydraulically-actuated, wet disc brakes actuate on four wheels.

**Parking brake:** Wet, multi-disc brake on transfer output shaft.

**Emergency brake:** Parking brake is commonly used.



### STEERING SYSTEM

Type.....Full-hydraulic power steering independent of engine rpm  
 Steering angle.....40° each direction  
 Minimum turning radius at the center of outside tire.....4880 mm 16'0"



### BUCKET CONTROLS

The use of a PPC hydraulic control valve offers lighter operating effort for the work equipment control levers. The reduction in the lever effort and travel makes it easy to operate in the work environment.

#### Control positions

Boom.....Raise, hold, lower, and float  
 Bucket.....Tilt-back, hold, and dump



### HYDRAULIC SYSTEM

#### Capacity (discharge flow) @ engine-rated rpm

Maximum flow for loader circuit  
 Loader + steering pump.....61 + 95 ltr/min 16.1 + 25.1 U.S. gal/min  
 Pilot pump.....37 ltr/min 9.8 U.S. gal/min  
 (Gear-type pumps)

#### Relief valve setting

Loader.....203 kg/cm<sup>2</sup> 19.9 MPa 2,900 psi  
 Steering.....210 kg/cm<sup>2</sup> 20.6 MPa 3,000 psi

#### Control valve

2-spool open center type

#### Hydraulic cylinders

Loader and steering.....Double-acting, piston

| Hydraulic Cylinders | Number of Cylinders | Bore   |      | Stroke   |       |
|---------------------|---------------------|--------|------|----------|-------|
|                     |                     | mm     | in   | mm       | in    |
| Boom                | 2                   | 120 mm | 4.7" | 673.5 mm | 26.5' |
| Bucket              | 1                   | 130 mm | 5.1" | 493 mm   | 19.4' |
| Steering            | 2                   | 70 mm  | 2.8" | 453 mm   | 17.8' |

#### Hydraulic cycle time (rated load in bucket)

Raise.....5.9 sec  
 Dump.....1.4 sec  
 Lower (empty).....3.6 sec  
 Total cycle time.....10.9 sec



### SERVICE REFILL CAPACITIES

Cooling system.....17.0 ltr 4.5 U.S. gal  
 Fuel tank.....175.0 ltr 46.2 U.S. gal  
 Engine.....19.5 ltr 5.2 U.S. gal  
 Hydraulic system.....58.0 ltr 15.3 U.S. gal  
 Axle (each, front and rear).....18.0 ltr 4.8 U.S. gal  
 Transmission.....5.5 ltr 1.5 U.S. gal



### BUCKET SELECTION GUIDE

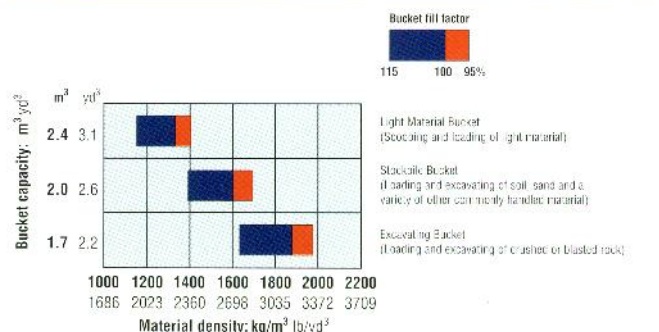





## STANDARD EQUIPMENT

- Alternator, 35A, 24 volt
- Axles, semi floating
- Back-up alarm
- Back-up light, rear
- Batteries, 110 Ah/2 x 12 V,
- Bucket positioner, automatic
- Cab (ROPS/FOPS) with cigarette lighter/ash tray, dome light, floor mat, front (intermittent) and rear wiper/washer, rear view mirrors (2 outside, 1 inside), right hand and left hand door access with steps, sun visor
- Counterweight
- Differentials, torque proportioning
- EMMS (Equipment Management Monitoring System)
  - Gauges (Speedometer, engine water temperature, fuel level, HST oil temperature)
  - LCD displays (filter/oil replacement time, HST selection, odometer, service meter, trouble shooting)
- Lights (Axle oil temperature, battery charge, brake oil pressure, central warning, directional indicator, engine oil pressure, engine pre-heater, HST oil filter clogging, high beam, maintenance, parking brake reminder, parking brake warning, steering oil pressure, transmission speed range, turn signals)
- Engine, Komatsu SAA6D102E-2-A
- Engine shut-off system, electric
- Engine water separator
- Fan, hydraulic driven, swing out
- Fenders, rear
- Hard water area arrangement (corrosion resister)
- Horn, electric
- Lift cylinders and bucket cylinder
- Lifting eyes
- Lights
  - Stop and tail
  - Turn signal (2 front, 2 rear)
  - Working (2 front, 2 rear, 2 outside cab)
- Loader linkage with standard lift boom
- Mono-lever loader control
- Parking brake, wet disc
- Radiator mask, hinged
- Seat belt, 3" wide
- Seat, rigid type, reclining with a document holder
- Service brakes, hydraulic, wet multi-disc, inboard
- Speedometer (km/h)
- Starting aid, intake manifold preheater
- Starting motor, 4.5 kW/24 V
- Steering wheel, tiltable
- Tires 17.5-25-12PR (L2), tubeless and rims
- Transmission (Hydrostatic with speed range select), automatic
- Transmission control, electric, steering column
- 2-spool valve for boom and bucket controls with PPC



## OPTIONAL EQUIPMENT

- Air conditioner with heater/defroster/pressurizer
- Alternator, 60A, 24V
- Auxiliary steering
- Boom kick-out
- Bucket, excavating, **1.7 m<sup>3</sup>** 2.2 yd<sup>3</sup>
- Bucket, stockpile, **2.0 m<sup>3</sup>** 2.6 yd<sup>3</sup>
- Bucket, light material, **2.4 m<sup>3</sup>** 3.1 yd<sup>3</sup>
- Bucket teeth, bolt-on
- Cold area arrangement
- Counterweight, additional
- Cutting edge, bolt-on, reversible
- ECSS (Electronically Controlled Suspension System)
- Fenders, front
- Fenders, rear full
- Heater and defroster
- Hydraulic adapter kit (3rd spool), includes valve, lever, and piping
- Limited-slip differential, front and rear
- Radio, AM/FM
- Radio, AM/FM stereo with cassette
- Rims only, less tires
  - Fits 17.5-25 and 20.5-25 tire
- ROPS canopy
- Seat, cloth, suspension, reclining with armrests, headrest, and a document holder
- Seat, vinyl, suspension, reclining with armrests, headrest, and a document holder
- Seat belt, retractable, 3" wide
- Spare parts
- 3-spool valve, lever, piping
- Tires (bias ply)
  - 17.5-25-12PR (L3)
  - 20.5-25-12PR (L2)
  - 20.5-25-12PR (L3)
- Tool kit
- Vandalism protection kit

**KOMATSU**®