

# KOMATSU

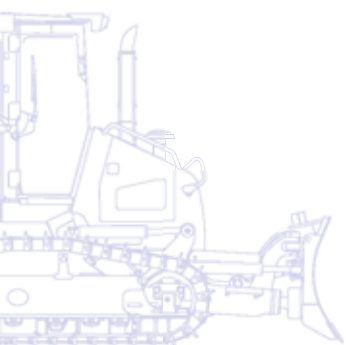

Crawler Dozer

## **D51EX/PX-22**



**ENGINE POWER**

99,0 kW / 133 HP @ 2.200 rpm

**OPERATING WEIGHT**

D51EX-22: 12.710 kg

D51PX-22: 13.100 kg

# Walk-Around

The Komatsu D51EX/PX-22 dozers offer reliability, versatility - and the best value for your money. Their hydraulics, power train and frame, and all other major components are directly engineered by Komatsu, and work together to deliver optimal production levels. A super-slant nose and rear mounted cooler make them unique on the market today.

## Unmatched visibility and safety

- Unique super-slant nose
- Cab-forward design
- Integrated ROPS/FOPS

## High productivity & low fuel consumption

- Meets EU Stage IIIA and EPA Tier III
- Highly efficient hydrostatic drive line
- High capacity Power Angle Tilt blade
- Electronically-controlled, hydraulically-driven fan



# D51EX/PX-22

**ENGINE POWER**  
99,0 kW / 133 HP @ 2.200 rpm

**OPERATING WEIGHT**  
D51EX-22: 12.710 kg  
D51PX-22: 13.100 kg

## First-class operator comfort

- Outstanding 360° visibility
- Large and quiet pressurized cab
- Easy control with Palm Command Control System joysticks (PCCS)
- Air-suspended driver seat positioned close to centre of gravity



## Easy maintenance

- Rear-mount radiator with swing-up hydraulic fan
- Monitor with self-diagnostic function
- Simple and convenient access to service points



## High reliability and durability

- New Komatsu PLUS undercarriage (standard)
- Modular power train design
- Heavy-plate steel used throughout
- Main frame made with welded and cast parts

**KOMTRAX**

Komatsu Satellite  
Monitoring System

# Unmatched Visibility and Safety

## The best view

A super slant nose gives the D51EX/PX-22 the best visibility of any dozers on the market. This unique feature dramatically increases efficiency and jobsite safety, with operators now always having full view of both the blade and the ripper and of objects close to them. The new cab-forward design, with integrated ROPS/FOPS and large glass windows, provides more room and places the operator closer to the blade, further improving visibility and comfort.

## Safe and easy access

For a safer entry and exit - and maximum operator protection, the D51EX/PX-22 includes numerous hand-rails and access steps both inside and outside the cabin. It is also easier to refuel or clean windows, or to reach most service points.





# High Productivity & Low Fuel Consumption

## A clean, powerful engine

A powerful yet fuel-efficient engine makes the D51EX/PX-22 an outstanding performer both for dozing and ripping. This 99 kW / 133 HP ecot3 engine features a new combustion chamber design with optimised ignition and combustion timing. The operating pressure of the new common rail system was increased for improved injection and fuel efficiency. The air-to-air intercooler reduces the temperature of the compressed air supplied by the turbo charger to the cylinders, and further improves fuel consumption.

## Meets EU Stage IIIA

The new Komatsu ecot3 technology reduces NOx and particle emissions, fuel consumption and noise level. The Komatsu SAA6D107E-1 engine is certified for EU Stage IIIA and EPA Tier III emission regulations.

## Highly efficient hydrostatic drive line

The hydrostatic drive line is a key factor in the performance of the D51EX/PX-22 dozer. It supplies high drawbar pull when needed and a highly fuel efficient drive line for grading and precision work. With a choice between two operating modes, the operator can select either “quick-shift” or “variable speed” to match a complete range of applications in the most economic and easy way.

## Hydrostatic transmission (HST) control system

The unique, Komatsu-designed hydrostatic transmission controller monitors the engine output and working equipment or travel load. It controls the HST pumps and motors displacement to deliver optimum speed and drawbar pull. In addition, the controller provides ample power to both tracks when turning, enabling counter rotation at very low speeds and making the D51EX/PX-22 extremely manoeuvrable.

## Automatic speed change

Komatsu HST controller always changes the travel speed automatically, depending on load or ground conditions, and efficient operations are facilitated – with no shift shocks. The dozer can work at the optimal speed and drawbar pull point, increasing productivity and fuel efficiency.



1. Engine speed indication
2. Pre-set button reverse speed
3. Pre-set button Quick shift/variable speed setting





## Efficient hydrostatic engine cooling fan

The cooling fan always runs at the lowest convenient speed. Rotation and velocity are electronically adjusted based on the temperature of the engine coolant and hydraulic oil. This reduces fuel consumption and operating noise levels, and requires less horsepower than a belt-driven fan. For extra efficiency, the fan also has a large air outlet surface, and the complete inlet area is protected by a fine grid, to prevent small particles from entering the fan area.



# First-Class Operator Comfort

## A smooth ride and lower noise levels

The cab on the D51EX/PX-22 was moved forward, and operators now sit closer to the centre of gravity of the machine. With the ripper still easily within eyeshot, they enjoy the best view of the blade, the lowest vibration levels and the highest stability of any dozer on the market. Silicon oil filled cab damper mounts isolate the operator compartment from the machine body and suppress vibrations, providing a quiet, comfortable operating environment. A new unique location for the radiator - at the rear of the machine - and the low speed of the hydraulically driven cooling fan further reduce noise levels.

## Pressurised cab

The integrated ROPS/FOPS cab's new design and large, tinted windows ensure excellent visibility in all directions. Superior cab sealing, air filters and raised internal air pressure prevent dust from getting into the cab. In addition, the high-quality interior is lined with sound-absorbent material.

## Easy operation control

The ergonomic Palm Command Control System (PCCS) provides efficient and comfortable steering of the machine, and the blade control joystick utilizes Proportional Pressure Control (PPC) for precise operations, excellent and easy grading jobs - and improved productivity.

## Fully-adjustable air suspension seat

The driver's seat and console are amongst the most important components of the driver's equipment. The comfortable, heavy-duty, air suspension seat, complete with headrest, gives the operator a secure and comfortable work environment.







# High Reliability and Durability

## Low-drive “PLUS” undercarriage

Komatsu’s new low-drive Parallel Link Undercarriage System (PLUS) is extraordinarily tough, with an excellent grading performance and stability. It features PLUS link assemblies, a new highly reliable floating bushing concept, substantial track link height, superior oil seals and newly designed track guards to maximise undercarriage durability. For easier servicing, the equalizer bar’s centre pin can be remotely greased. The segmented sprockets can be changed individually and by hand, so a single mechanic can carry out replacements at the jobsite.

## EX undercarriage

The EX undercarriage has been specially designed for working on hard ground. The small to medium-width shoes and PLUS link assembly ensure a large contact area between the machine and the ground for maximum stability, grading performance and undercarriage lifetime.

## PX undercarriage

The PX undercarriage is ideal for working on soft surfaces. The wide shoes and PLUS link assembly ensure a large contact area between the machine and the ground for maximum stability, grading performance and undercarriage lifetime.

## Modular design

D51EX/PX-22 was designed and manufactured to have low maintenance costs and a long lifetime. This was achieved mainly by reducing component complexity and with a strong modular design.

## Improved rigidity and durability

Komatsu’s monocoque track frame uses thicker box section material, and the machine’s main frame is a highly-rigid simple hull with thick plates and steel casting. Both frames have fewer welded components and combine to provide increased strength, rigidity and durability to the D51EX/PX-22.

## Self-adjusting idler support

The self-adjusting idler support provides constant and even tension on idler guide plates. It reduces noise levels and vibrations and increases undercarriage life.



*Self-adjusting idler support*



*High-rigidity simple hull frame structure*



*The new Komatsu PLUS undercarriage:  
When conventional undercarriages are  
long gone, the PLUS undercarriage  
keeps going strong.*

# Easy Maintenance

## Simple and convenient service

Well located service doors allow convenient and safer ground access to daily service points. With the radiator located at the rear of the machine, engine fuel and oil filters can be easily accessed from the front of the engine compartment. Remote grease points facilitate lubrication of the C-frame pivots and angle cylinder bearing.

## Engine protection

A large, double air filter ensures maximum engine protection. Fuel passes through a pre-filter with a water separator and a special final filter, maximising the engine's lifetime and minimising maintenance costs. The engine cooling fan position at the back of the machine significantly reduces dust levels at the engine air intake. This intake has a rain cap as standard and a turbo type pre cleaner in option for very dusty environments and to lengthen the intervals between the cleaning of the air filters.

## Self-diagnostic monitor

The multi-function monitor panel displays the running time, engine revs, fuel level and water coolant temperature in real time. It also provides the operator with maintenance and service information, if oil filters need replacing or any abnormality occurs. In addition, it supplies Komatsu mechanics with detailed information, with no need for external service tools.

## Protected hydraulic piping

Komatsu has designed the hydraulics of the working equipment so it minimises maintenance costs. All the hydraulic lines are well protected with special linings and embedded into the steel structures whenever possible.



*Unique front-side access*



*Segmented sprocket*





## Reversible swing-up fan

The D51EX/PX-22 includes a swing-up fan with a gas strut-assisted lift locking system to provide easy access to the radiator, oil cooler, and charge air cooler. The operator can switch the hydraulic fan to “cleaning” mode so that it rotates in reverse at full speed to clean the radiators, reducing maintenance costs and improving fuel efficiency.



# Komatsu Satellite Monitoring System



KOMTRAX™ is a revolutionary machine tracking system designed to save you time and money. You can now monitor your equipment anytime and anywhere. Use valuable machine data received via the KOMTRAX™ web site to optimise your maintenance planning and machine performances.

KOMTRAX™ can assist you with:

## **Full machine monitoring**

Get detailed operation data to know when your machines are used and how productive they are.

## **Total Fleet Management**

Keep track of the location of your machines at all times and discourage unapproved usage or theft.

## **Complete machine status**

Receive warnings, alerts and cautions, via a web site or by e-mail, to help with maintenance planning and for longer machine life.

For further details on KOMTRAX™, please ask your Komatsu dealer for the latest KOMTRAX™ brochure.





*Machine working time - With the “daily working record” chart, get precise engine running time data: when your machine was started and when it was shut down, as well as total engine running time.*



*Maintenance planning - To increase productivity and improve maintenance planning, alerts indicate when items such as filters or oil must be replaced.*



*Fleet location - The machine list instantly locates all your machines, even those in other countries.*



*Machine tracking during transport - When your machine is transported, KOMTRAX™ sends travel messages to the web site or by e-mail to inform you of its progress, and confirms when it reaches its destination.*



*Alarm notifications - You can receive notification of alarms both via the KOMTRAX™ website and by e-mail.*



*Added security - The “engine lock” feature allows to program when a machine’s engine can be started. And with “geo-fence”, KOMTRAX™ sends notification every time your machine moves in or out of a predetermined operating area.*



# Work Equipment

## Komatsu blades

Komatsu uses a box blade design, offering the highest resistance for a low weight blade. This increases total blade manoeuvrability and machine balance. High-tensile-strength steel was incorporated into the front and sides of the blade for increased durability. The blade shape design makes it easy to handle a wide range of materials, offering good blade penetration combined with a low blade rolling resistance. Komatsu blades help to deliver excellent fuel efficiency.

## Straight Power Angle Tilt blade

The straight Power Angle Tilt blade (PAT), offers a wide range of working modes. The new centreball design, with a large ball diameter, offers a strong and durable solution for the blade attachment to the Inpat frame reducing maintenance costs.

## Komatsu rippers

Komatsu rippers were designed to combine the highest productivity with a long lifetime. The shank is fitted with special wear parts that increase longevity, and offer the best penetration in various types of materials.

## Multishank parallelogram ripper (EX) (option)

The multishank parallelogram ripper has 3 ripper shanks as standard, but can be easily converted to a giant or two-shank ripper, depending on job conditions. The strong parallelogram design offers straight shank movement, adapted for different jobsite applications.

## Komatsu-Topcon machine control systems

Automatic blade movements on a dozer greatly improve dozing productivity and grading accuracy. They also allow operators to work faster and more safely with a reduced workload. Komatsu-Topcon machine control systems are the best way to automate blade movements. Depending on the control system used, blade movement can be monitored or fully automated. As a result, even inexperienced operators work much faster and deliver a high-quality final graded area. All the information from the laser or GPS systems is constantly available on an in-cab display, clearly showing the slope and elevation.

Two different systems for Komatsu dozers are available.

Two-dimensional (2D): allow creation of flat areas, possibly combined with a slope depending on the configuration. These systems are based on one or two laser signal receivers and/or a slope sensor installed on the dozer blade.

Three-dimensional (3D): allow any complicated landscape design to be made. This requires GPS receivers, and can be extended with a laser zone system for millimetre accuracy.







# Specifications

## ENGINE

Model ..... Komatsu SAA6D107E-1  
 Common rail direct injection, water-cooled, emissionised, turbocharged, after-cooled diesel

Engine power  
 at rated engine speed ..... 2.200 rpm  
 ISO 14396 .....99,0 kW / 133 HP  
 ISO 9249 (net engine power) .....97,0 kW / 130 HP

No. of cylinders ..... 6  
 Bore x stroke.....107 x 124 mm  
 Displacement.....6,69 ltr  
 Governor.....All-speed, electronic  
 Fan drive type.....Hydraulic  
 Lubrication system  
 Method.....Gear pump, force lubrication  
 Filter .....Full flow

## HYDROSTATIC TRANSMISSION

Dual-path, hydrostatic transmission provides infinite speed changes up to 9,0 km/h. The variable capacity travel motors allow the operator to select the optimum speed to match specific jobs. Travel control lock lever and neutral switch.

## MAX. TRAVEL SPEEDS

Quick shift mode	Forward	Reverse
1st	0 - 3,4 km/h	0 - 4,1 km/h
2nd	0 - 5,6 km/h	0 - 6,5 km/h
3rd	0 - 9,0 km/h	0 - 9,0 km/h

Variable speed mode	Forward	Reverse
	0 - 9,0 km/h	0 - 9,0 km/h

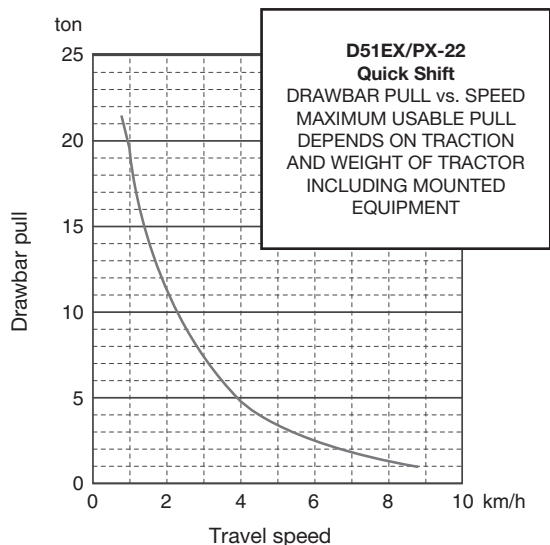

## FINAL DRIVE

Type..... Planetary gear, double-reduction  
 Sprocket..... Segmented sprocket teeth are bolt-on for easy replacement

## STEERING SYSTEM

Type..... Hydrostatic Steering System (HST)  
 Steering control ..... PCCS-lever  
 Service brakes.....Hydraulic dynamic brake, pedal-controlled  
 Minimum turning radius (counter-rotation)  
 D51EX-22..... 1,81 m  
 D51PX-22 ..... 1,89 m  
 As measured by track marks on the ground.

## UNDERCARRIAGE

Suspension..... Oscillating equaliser bar and pivot shaft  
 Track roller frame ..... Monocoque, large section, durable construction  
 Tracks..... PLUS link assembly  
 Track tension..... Combined spring and hydraulic unit  
 Number of shoes (each side)..... 44  
 Grouser height (single grouser) ..... 54 mm  
 Track rollers (each side) ..... 7  
 Carrier rollers (each side)..... 2  
 Shoe width (standard)  
 D51EX-22.....560 mm  
 D51PX-22 .....710 mm  
 Ground contact area  
 D51EX-22.....30.744 cm<sup>2</sup>  
 D51PX-22 .....38.979 cm<sup>2</sup>  
 Ground pressure  
 D51EX-22.....0,41 kg/cm<sup>2</sup>  
 D51PX-22 .....0,34 kg/cm<sup>2</sup>

## OPERATING WEIGHT (APPR.)

Including PAT blade, steel cab, operator, rated capacity of lubricant, coolant, and full fuel tank.

D51EX-22..... 12.710 kg  
 D51PX-22 ..... 13.100 kg

## SERVICE REFILL CAPACITIES

Fuel tank .....270 ltr  
 Radiator..... 35 ltr  
 Engine oil.....20 ltr  
 Final drive (each side).....4,0 ltr  
 Hydraulic tank ..... 63 ltr

## ENVIRONMENT

Engine emissions ..... Fully complies with EU Stage IIIA and EPA Tier III exhaust emission regulations  
 Noise levels  
 LwA external ..... 106 dB(A) (2000/14/EC Stage II)  
 LpA operator ear.....80 dB(A) (ISO 6396 dynamic test)

## DIMENSIONS

	D51EX-22	D51PX-22
A	1.280 mm	1.280 mm
B*	3.045 mm	N/A
B**	3.350 mm	3.350 mm
C*	459 mm	N/A
C**	505 mm	505 mm
D	2.885 mm	2.885 mm
E	1.107 mm	1.107 mm
F	461 mm	461 mm
G	2.745 mm	2.745 mm
H	4.800 mm	4.800 mm
I	2.245 mm	2.245 mm
J	3.177 mm	3.177 mm
K	2.997 mm	2.997 mm
L	55 mm	55 mm
M	1.790 mm	1.880 mm
N	560 mm	710 mm
O	2.350 mm	2.590 mm
P*	4 mm	N/A
P**	136 mm	16 mm
Q*	2.725 mm	N/A
Q**	2.990 mm	2.990 mm

\* 2,7 m<sup>3</sup> blade (D51EX-22 only)

\*\* 2,9 m<sup>3</sup> blade

2,7 m<sup>3</sup> blade foldable (D51EX-22 only): transport width 2.550 mm

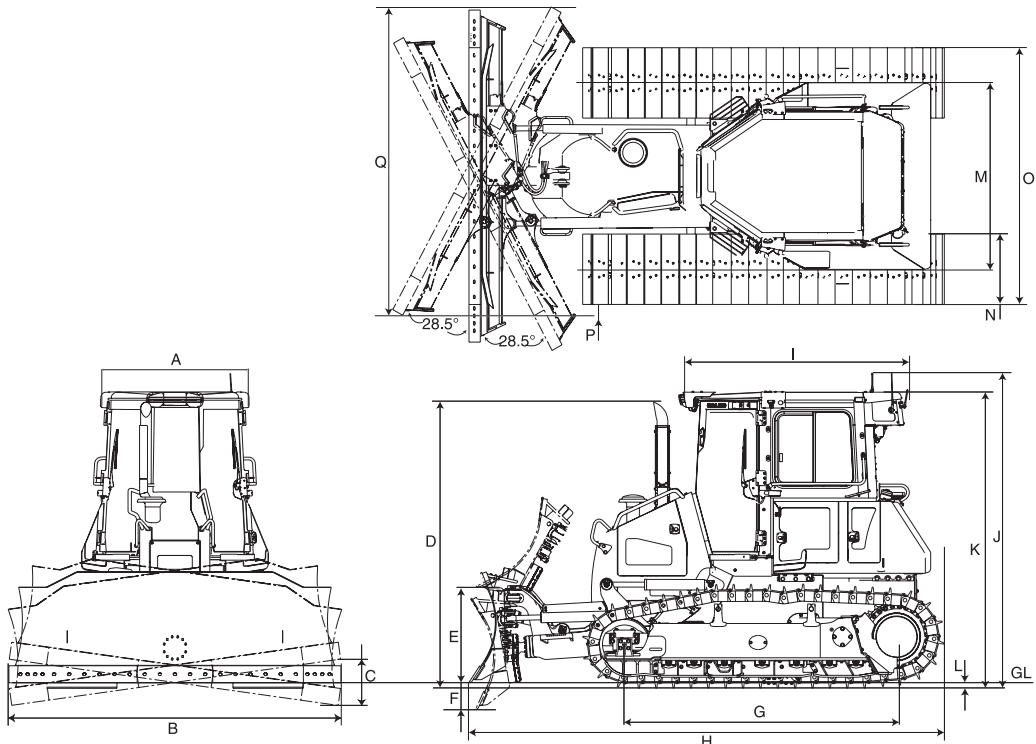

Ground clearance: 385 mm

## HYDRAULIC SYSTEM

Type.....CLSS (closed-centre load sensing system)  
 All spool valves externally mounted beside the hydraulic tank.  
 Maximum pump flow.....99 ltr/min  
 Relief valve setting .....274,6 bar  
 Spool control valve positions  
 Blade lift..... Raise, hold, lower, and float  
 Blade tilt..... Right, hold, and left  
 Additional control valve positions for ripper  
 Ripper lift ..... Raise, hold, and lower  
 Hydraulic cylinders..... Double-acting, piston  
 No. of cylinders × bore  
 Blade lift.....2 × 90 mm  
 Blade tilt.....1 × 100 mm  
 Blade angle.....2 × 90 mm  
 Ripper lift .....1 × 110 mm

## RIPPER EQUIPMENT

Multishank ripper  
 Type..... Hydraulically controlled parallelogram ripper  
 No. of shanks .....3  
 Weight (including hydraulic control unit) ..... 850 kg  
 Beam length .....1.550 mm  
 Maximum lift above ground.....378 mm  
 Maximum digging depth .....428 mm

## DOZER EQUIPMENT

	Overall length with dozer	Blade width × height	Maximum lift above ground	Maximum drop below ground	Maximum tilt adjustment	Blade angle
2,7 m <sup>3</sup> PAT blade (EX)	4.800 mm	3.045 × 1.110 mm	1.107 mm	461 mm	459 mm	28,5°
2,7 m <sup>3</sup> PAT blade foldable (EX)	4.800 mm	3.045 × 1.110 mm	1.107 mm	461 mm	459 mm	28,5°
2,9 m <sup>3</sup> PAT blade (EX)	4.800 mm	3.350 × 1.110 mm	1.107 mm	461 mm	505 mm	28,5°
2,9 m <sup>3</sup> PAT blade (PX)	4.800 mm	3.350 × 1.110 mm	1.107 mm	461 mm	505 mm	28,5°

Blade capacities are based on the SAE recommended practice J1265.

# Crawler Dozer

## D51EX/PX-22

### Standard and Optional Equipment

#### ENGINE AND RELATED PARTS

Komatsu SAA6D107E-1 turbocharged direct injection diesel engine	●
EU Stage IIIA/EPA Tier III compliant	●
Fuel pre-filter (10 micron) and fuel filter (2 micron)	●
Exhaust pipe with elbow	●
Intake pipe with rain cap	●
Alternator 24 V/60 A	●
Starter motor 5,5 kW/24 V	●
Batteries 200 Ah/2 × 12 V	●
Intake pipe with air pre-cleaner	○

#### TRANSMISSION AND BRAKES

Electronically controlled HST	●
Palm lever steering control (PCCS)	●
Quick shift selection system	●
Variable speed mode	●
Reverse speed presets	●
Decelerator pedal	●
Combined inch/brake pedal	●

#### UNDERCARRIAGE

Single grouser heavy-duty shoes (EX: 560 mm; PX: 710 mm)	●
Komatsu PLUS link assembly	●
Segmented sprockets	●
Idler cushions	●
Track roller guard, centre and end section	●
Full length track roller guard	○

#### SERVICE AND MAINTENANCE

Swing-out hydrostat-driven radiator fan with reversing function	●
Dry type air cleaner, double element with dust indicator and evacuator	●
Water separator	●
Electronic monitor panel with self-diagnostic function and maintenance display	●
KOMTRAX™ - Komatsu satellite monitoring system	●
Tool kit	●

#### CABIN

Air suspension seat: fabric, reclining, high backrest	●
Seat belt	●
High mount footrest	●
Air conditioner	●
Pre radio installation kit (12 V, antenna, loudspeakers)	●
12 Volt power supply (120 W)	●
Viscous cab mounts	●
Rear-view mirror (inside cab)	●
Wiper front window	●
Wiper rear window	●
Wipers doors	●
Cup holder	●
Lunch box holder	○

#### HYDRAULIC SYSTEM

Hydraulics for dozing blades	●
Mono lever blade control	●
Hydraulics for ripper (EX only)	○

#### LIGHTING SYSTEM

Working lights, 3 cab roof front, 1 cab roof rear	●
---	---

#### SAFETY EQUIPMENT

Steel cab, meets ISO 3471 and SAE J1040, APR88 ROPS standards, as well as ISO 3449 FOPS standards	●
Horn	●
Locks, filter caps and covers	●
Back-up alarm	●
Fire extinguisher	○

#### ATTACHMENTS

Front pull hook	●
Hitch (not with ripper)	●
Rigid drawbar	○

#### DOZER EQUIPMENT

2,7 m³ PAT blade (EX)	○
2,7 m³ PAT blade foldable (EX)	○
2,9 m³ PAT blade (EX)	○
2,9 m³ PAT blade (PX)	○
Multishank parallelogram ripper (EX only)	○
Komatsu-Topcon machine control systems	○

Further equipment on request

- standard equipment
- optional equipment

Your Komatsu partner:

# KOMATSU

**Komatsu Europe  
International NV**

Mechelsesteenweg 586  
B-1800 VILVOORDE (BELGIUM)  
Tel. +32-2-255 24 11  
Fax +32-2-252 19 81  
[www.komatsu.eu](http://www.komatsu.eu)

EESS018901 03/2009

Materials and specifications are subject to change without notice.  
**KOMATSU** is a trademark of Komatsu Ltd. Japan.